

STQ YA3 3001K SPEED KIT

For Yamaha G14/G16 Electric Models



Installation Instructions

We would like to thank you for purchasing our exclusive STQ YA3 3001K SPEED KIT. We take great pride in our products and feel certain that this kit will offer you many years of trouble-free service. We ask that you take a moment to read these instructions completely before beginning your installation. Familiarity with the parts and an understanding of the procedures will ensure that your installation goes smoothly and safely. Additionally, it will give you an opportunity to determine if your cart might have any damaged, corroded, or missing parts, which will need replacing prior to using your new speed kit.

ABOUT THIS SPEED KIT

This speed kit is designed specifically for Yamaha 36 volt electric G14/G16 model golf carts. If you are unsure of your golf cart type, please see our catalog or contact our technical department, toll free at 1-1-888-444-9994, or online at www.buggiesunlimited.com. During the installation of this kit you will be upgrading three major electrical components from your golf cart, with three high performance components in our STQ YA3 3001K SPEED KIT. These parts are: the motor, the speed controller, and the solenoid. All of your electrical connections will be made between these components and either the battery group or a device called a forward/reverse switch. You should allow about 4 hours for installation.

PARTS INCLUDED IN OUR KIT

- 1) Electric motor (per application).
- 2) High Performance speed controller (24/36V)
- 3) Electric solenoid (High Performance, 36V).
- 4) 6 gage cable kit including:
 - a) 4 red coded cables.
 - b) 1 blue coded cable.
 - c) 1 white coded cable.
 - d) 1 orange coded cable.
 - e) 1 black coded cable.
 - f) 5 red/black coded cables.
- 5) Bridge Resistor.
- 6) Hardware kit.



Buggies Unlimited
1-888-444-9994
www.buggiesunlimited.com

TOOLS AND MATERIALS REQUIRED TO INSTALL KIT

- 1) SAE socket set, with ratchet and 3” and 6” extensions.
- 2) SAE combination wrench set.
- 3) #2 Phillips and Flat Tip screwdrivers.
- 4) Wire cutters.
- 5) Wire Terminal Crimper.
- 6) Heavy weight grease.
- 7) Safety Goggles/Glasses.



ADDITIONAL TOOLS WHICH MAKE THE JOB BETTER AND FASTER

- 1) Battery Carrying Strap. Part # BTA UNV 1001.
- 2) Battery Terminal Protector Spray. Part # MNT UNV 0512.
- 3) Battery Terminal Re-facer. Part # TLS UNV 6002.
- 4) Electronic Multi-meter. Part # MET DIG OHM.
- 5) Small Box of Baking Soda. Local store purchase.



BTA UNV 1001



MNT UNV 0512



TLS UNV 6002



MET DIG OHM



A NOTE BEFORE STARTING

Throughout this installation, we will be discussing the connection of #4 heavy gauge cables to several different electrical components. Some cables will be attached to **THREADED LUGS** or “posts”, and others will be attached to **FLAT BUS BARS**. An understanding of each of these cable connections is important. Let’s first cover the **THREADED LUGS**. You will notice these lugs utilize a set of double nuts to hold the cable terminal firmly in place. Typically, a cable terminal and a washer will be sandwiched between these two nuts. This configuration is deliberate, and care should be given to properly removing or installing these nuts. An open-end wrench of the appropriate size should be held on the bottom nut while another wrench or socket is used on the top nut to either loosen or tighten this connection. The use of opposing wrenches relieves the threaded lug of excessive stress and eliminates the possibility of damaging the seals at the base of these lugs. Failure to use the opposing wrench technique on double-nutted lugs can permanently damage the component. You will also want to use the opposing wrench technique when making connections at the **FLAT BUS BARS**, but care should also be given to avoid twisting or bending the bars. Again, these seals at the base of the connection points are fragile and subject to damage if handled improperly. Seal damage at these electrical contact points will **void** the warranty for that component.

INSTALLATION

1) **SEAT CUSHION REMOVAL:** Grasp the handles and rotate forward. The cushion hinges to the front of the cart, and will simply lift off when it's in the vertical position.



2) **ACCESS PANEL REMOVAL:** Remove the black plastic rear access panel located behind the seat, which is secured using Phillips screws.



3) **BATTERY REMOVAL:** There are two things to take note of here: Battery placement and wiring layout.

NOTE: Battery acid can be very damaging...wear rubber gloves, eye protection, and old clothes. Work in a well-ventilated and appropriate area for the task. Battery residue can stain concrete. Observe the position and orientation of the battery group, as you will want to reinstall all the batteries in the same manner. Failure to orient the batteries correctly can leave some wires too short or too long for their intended purpose. Hint: As you remove and set the batteries aside, place them in a grouping just as they appeared in the battery tray of your cart. This will leave no doubt as to their original position. Also take note of your battery cables. You'll see that the batteries are always connected to each other in a series configuration...that is "positive" to "negative" to "positive" to "negative" and so on through all six batteries. Confirm that your battery cables appear like those in the wiring diagram, and remove all existing wiring from the batteries. There will be other smaller wires connected to some of the batteries on your cart. Write down the location of those smaller wires, as you will be reinstalling them in those same locations after you have completed the installation of the speed kit. Hint: Labeling the wires with a small piece of masking tape will go a long way in avoiding confusion upon reinstallation. Once you have made the above notations and removed the cables and wires, you can release the batteries by using a 1/2" socket to remove the two nuts and washers on the bolts of the hold-down plate centered in the battery grouping. **Note:** Use care in lifting the batteries from the cart...they are very heavy. A battery carrying strap makes this job much easier.

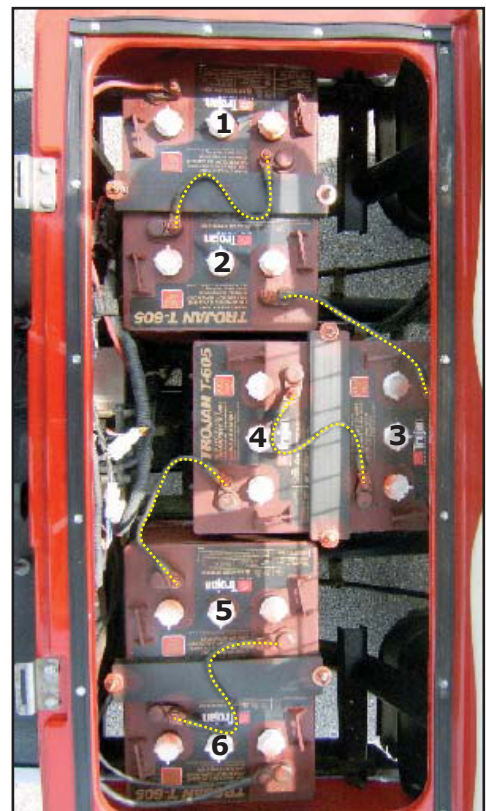

4) FORWARD/REVERSE SWITCH WIRE REMOVAL:

Locate the forward/reverse switch assembly, which is found in the front center of the rear body, directly below the seat. Remove all four heavy gauge cables from the switch assembly and retain the factory hardware for reinstallation of your new cables. See the wiring diagram for a visual representation of the forward/reverse switch assembly.

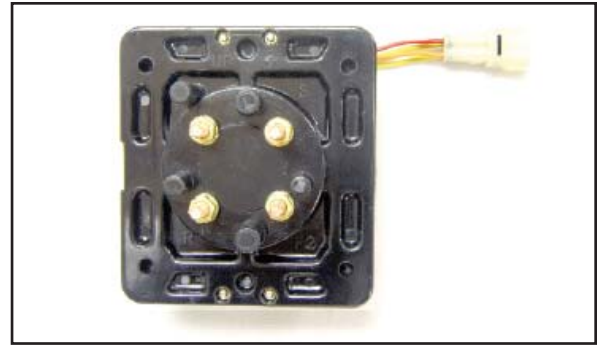

4a. Forward/Reverse Switch (Back)

5) SPEED CONTROLLER AND SOLENOID REMOVAL:

Directly below the forward and reverse switch assembly you will find the speed controller. The solenoid is located off to the side of the controller towards the passengers side. The speed controller is the small metal box and the solenoid is the cylindrical device mounted beside the controller. Begin the removal of these components by first discharging the speed controller. Using a standard screwdriver, bridge the terminals marked “B-” and “B+”. You may see or hear a small spark and this is normal, and is an indicator that the capacitors inside the speed controller have been de-energized. Let’s begin with the SOLENOID (the cylindrical device). You will notice it has two large lugs and two smaller lugs. You will be replacing all the cables on the large lugs with cables from our new speed kit, but the wires attached to each of the smaller lugs will be kept and reattached to the new solenoid. Don’t forget to use the opposing wrench technique when removing these wires and cables. Moving on to the SPEED CONTROLLER. You will notice it has three large flat bus bars. Just like on the solenoid, you will be replacing the large cables on the speed controller with new cables from our STQ YA3 3001K SPEED KIT, but remember to use the opposing wrench technique to avoid twisting or bending of the bus bars. Once all of the wires and cables have been disconnected, release the mounting hardware of the controller and the solenoid and remove those components from the cart. Use the new hardware kit.

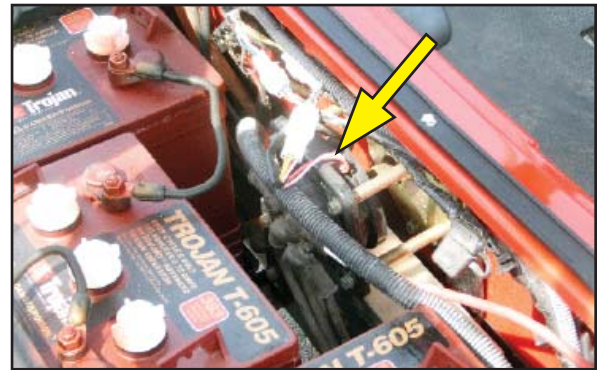

4b. Forward/Reverse Switch Location in Cart

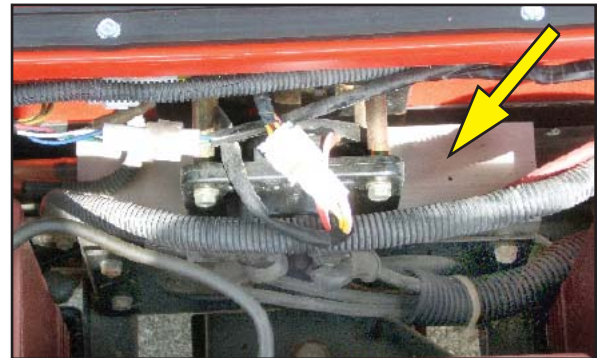

5a. Controller Location in Cart

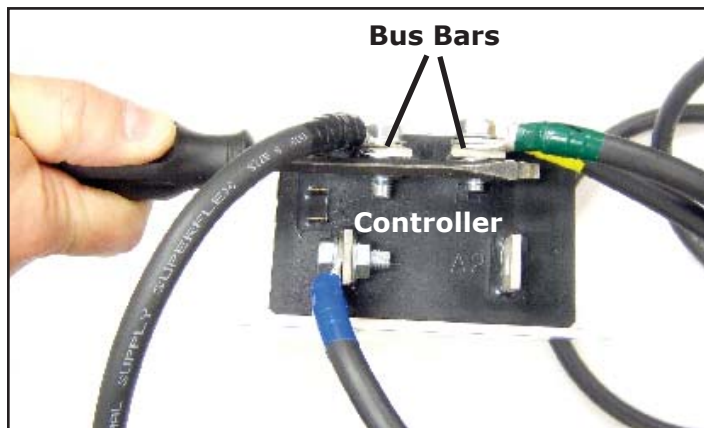

5b. Discharging the Controller

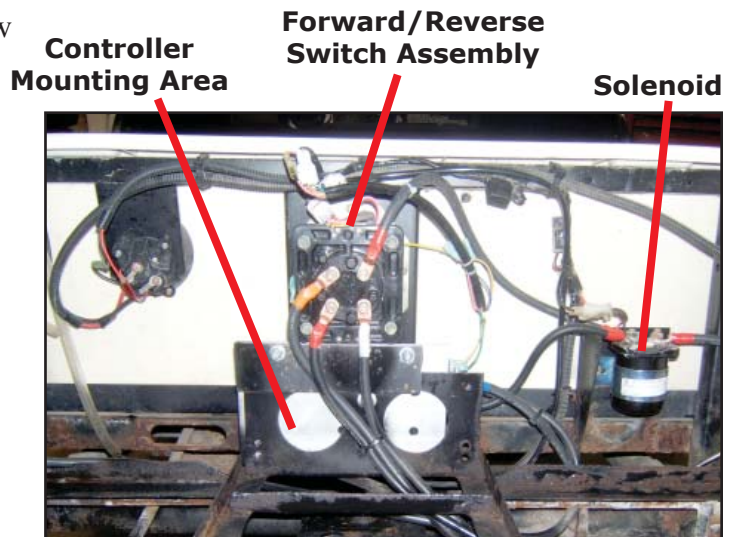

6) **FINAL CABLE REMOVAL:** You will find four large threaded electrical lugs on the case of the motor, with one cable connected to each lug. Remove these cables, remembering to use the opposing wrench technique. Once you have removed the cables from the motor, all of the heavy gauge cables in your cart should now be disconnected from their mounting points, and you may remove them from the cart, while taking note of the paths in which they were routed.

7) **MOTOR REMOVAL:** Before removing the motor, clean the surrounding area of any excessive mud or dirt, which may have accumulated on nearby parts. We want to ensure that internal parts stay as clean as possible. Once the area is clean, you will notice three hex head bolts on the transfer case, which bolt through to the motor. Using a 7/16" socket, remove these bolts to release the motor from the housing. If your cart has a cable-retaining loop fastened to one of the motor mount bolts, release that bolt first, and then remove the remaining two bolts. Carefully pull the motor from the housing. Some gentle back and forth pressure, while pulling the motor, should allow the motor to slide off the shaft. Use caution, as the motor is heavy and will drop quickly once it is free from the shaft.

8) **COMPONENT INSTALLATION PREPARATION:** Before installing the speed kit in your cart, take a little time to clean the areas now exposed by the removed components. The motor mount may have some grit or dirt around the opening of the mount. A moist rag or small brush can be used to clean that area. Avoid letting dirt fall into the housing. The battery trays may have dirt, leaves, or corrosion, which should be cleaned. For instruction on cleaning corrosion, see step 12. While the mounting surface of the controller should be quite clean, inspect it and wipe it down with a damp cloth to remove dirt or film. This area acts as a heat sink and dirt will interfere with its performance.

9) **MOTOR INSTALLATION:** Before mounting the motor, lubricate the splines of the motor shaft with quality heavy-weight grease...available at any auto parts store. Lifting the new motor up, slide it onto the shaft inside the motor mount housing. With some gentle back and forth movement and pressure toward the housing, the motor should mount up to the housing with little effort. Align the mounting holes of the housing and the mounting holes of the motor by rotating the motor slightly. When aligned properly, mounting bolts can be inserted. Observe a rotating or criss-cross pattern as you tighten the mounting bolts, to insure that the motor is not binding or stressed. Tighten securely...but avoid over tightening.



6. Motor Location in Cart



Opposing Wrench Technique

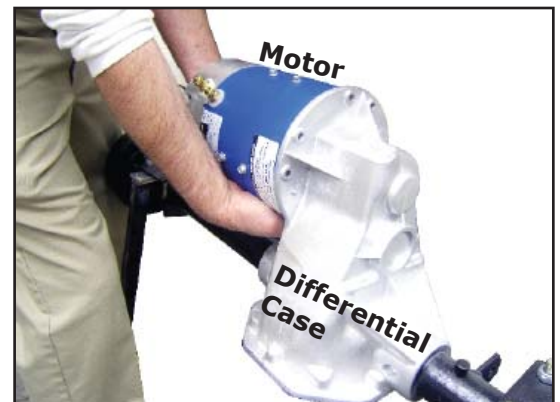

7. Gentle Back and Forth Pressure To Remove Motor



8. Clean the Motor Mount Area

10) CONTROLLER AND SOLENOID INSTALLATION:

Reference the controller bracket mounting diagram on page 11. **NOTE: NO drilling is required.** First, with the controller's bus bars facing to your right, insert the two 1/4" bolts through the top two holes on the controller. Next, place the smaller of the two metal brackets (called the shim) over the two bolts. Make sure the edge of the controller is aligned with the edge of the shim. Next place the larger metal bracket over the two bolts, on top of the shim. Again, making sure that the edge is aligned with the controller. Next, install the two nuts onto the bolts and hand tighten, making sure to leave some space for installation over the frame. Slide the controller and brackets over the existing mounting area on the cart. Slide the unit to where it is aligned to the driver's side of the mounting area. Notice that the shim will rest on top of the frame work. Tighten the bolts until the clamping action of the brackets firmly clamp the controller to the cart mounting area. Double check to make sure the controller terminals are facing the passenger side and are not touching any metal area. Using the original hardware, install the new solenoid in the same location as the original solenoid.

11) CONNECTING THE CABLES: It is now time to connect the cables to your controller, solenoid, forward and reverse switch, and motor. **Note: A2 connection on the controller is NOT used.**

- a) Locate the small resistor wire from the hardware pack. It is a short wire with a ring terminal on each end. This wire will jumper across the two large threaded terminals of the solenoid. Recall that the solenoid is one of the components which will have the double nuts installed on the terminals. Insure that the bottom nut is threaded onto each of the two large terminals, and then install the wire by placing one ring terminal over each large threaded terminal. It may be necessary to bend the wire slightly to make it fit... this is normal.
- b) Locate the red coded cable that is 23" long. Place one end of this cable onto the large threaded terminal of the solenoid, which will be closest to the batteries (or the passenger's side of the cart). Using 1/2" wrenches, tighten the connection securely using the lock washer and top nut provided. Remember to use the opposing wrench technique. The other end of this cable will be connected to the positive terminal of battery #1 after the batteries have been installed.

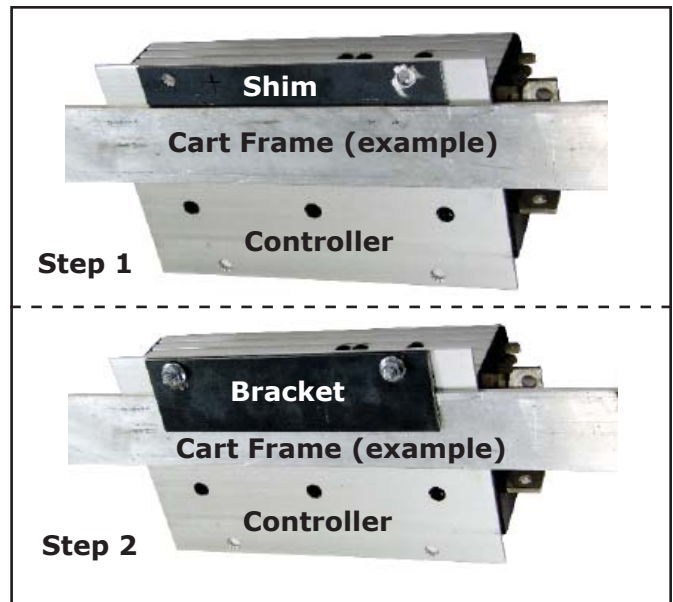

10a. Controller Bracket Installation

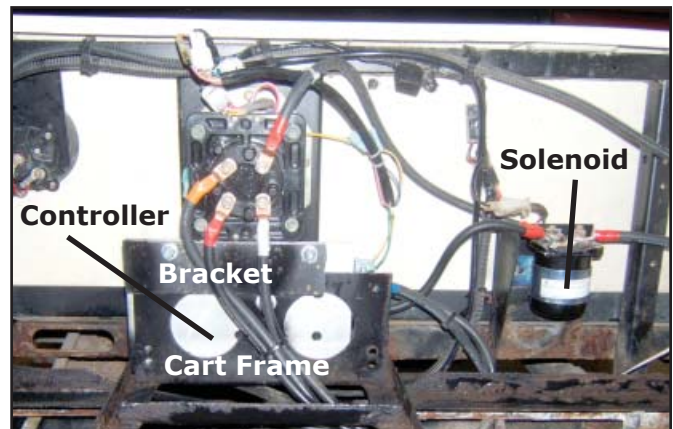

10b. Controller & Solenoid Installation

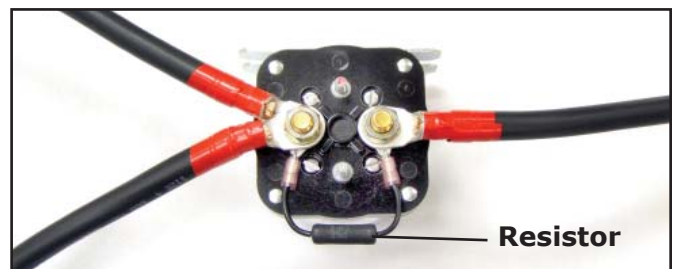

11a, b, c & e. Resistor & Red Cable Installation on Solenoid



11c. Red Cable Installation on Controller

- c) Locate the red coded cable that is 10” long and connect one end of this cable to the electric bus bar marked “B+” on the controller. Tighten the provided nut and bolt securely using 1/2” wrenches. Remember to use the opposing wrench technique and avoid twisting or bending the bus bar. The other end of this cable will be connected to the “B” terminal of the solenoid.

- d) Locate the red coded cable that is 36” long and connect one end of this cable to the threaded lug marked “A1” on the motor. Recall that the motor is one of the components that will have double nuts installed on the terminals. Ensure that the bottom nuts are threaded on each of the four (4) lugs of the motor. Using 1/2” wrenches, install the cable and tighten securely using the opposing wrench technique. The other end of this cable will be connected to “R” on the forward/reverse switch.

- e) Locate the red coded cable that is 16” long and connect one end of this cable to terminal “B” on the solenoid and the other end will connect to the “S” terminal of the forward and reverse assembly. Remember to use the opposing wrench technique and avoid twisting and over tightening. The lock washer must be compressed fully and the cable must not move.

- f) Locate the blue coded cable that is 35” long and connect one end of this cable to the threaded lug marked “A2” on the motor. Using 1/2” wrenches, install the top nut and tighten securely using the opposing wrench technique. Using a 1/2” wrench and the factory hardware, connect the other end of this cable to position “M-” of the controller switch assembly, as shown on the wiring diagram. Tighten securely, but use caution to avoid over tightening.

- g) Locate the orange coded cable that is 42” long and connect one end of this cable to “S1” on the motor. Tighten the provided nut and bolt securely using 1/2” wrenches. Remember to use the opposing wrench technique and avoid twisting or bending the bus bar. Using a 1/2” wrench and the factory hardware, connect the other end of this cable to position “F1” of the forward/reverse switch assembly, as shown on the wiring diagram. Tighten securely, but use caution to avoid over tightening.

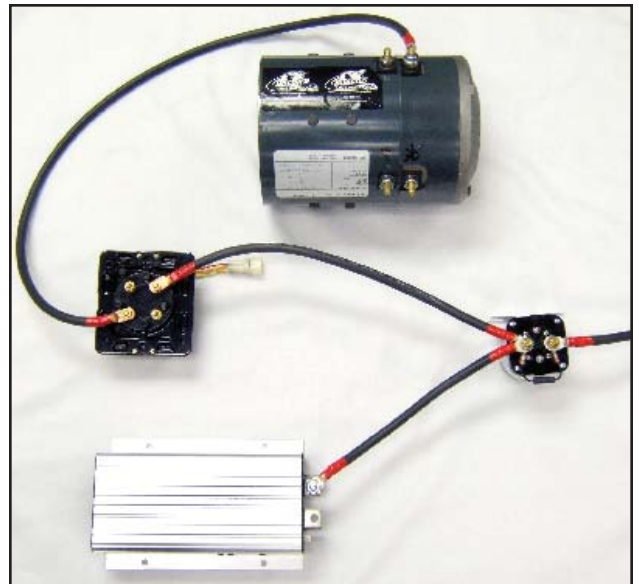

11a-e. Red Cable Installation



11f. Blue Cable Installation on Controller

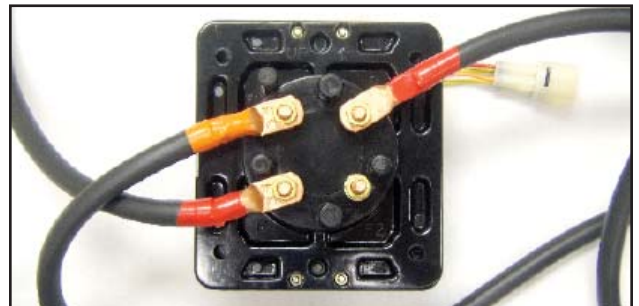

11d & g. Red and Orange Cable Installation on Forward/Reverse Switch



11d, f, g & h. Cable Installation on Motor

h) Locate the white coded cable that is 37" long and connect one end of the cable to the threaded terminal marked "S2" on the motor. Using 1/2" wrenches, install the top nut and tighten securely, remembering to use the opposing wrench technique. Using a 1/2" wrench and the factory hardware, connect the other end of this cable to position "F2" of the forward/reverse switch assembly, as shown in the wiring diagram. Tighten securely, but use caution to avoid over tightening.

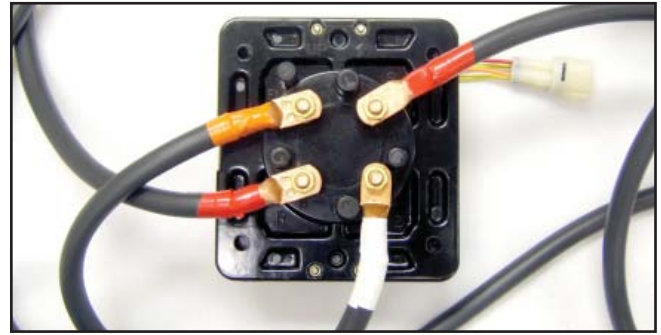

11h. White Cable Installation on Forward/Reverse Switch

i) Locate the black coded cable that is 55" long and connect one end of this cable to the electric bus bar marked "B-" on the controller. Tighten the provided nut and bolt securely using 1/2" wrenches. Remember to use the opposing wrench technique and avoid twisting or bending the bus bar. The other end of this cable will be connected to the negative terminal of battery #6 after the batteries have been installed.



11i. Black Cable Installation on Controller

12) BATTERY INSTALLATION: Before installing the batteries, there are a few steps you should take to insure optimal performance from your new STQ YA3 3001K SPEED KIT. Begin by giving your batteries a thorough cleaning. Dirt can be removed with a scrub brush and warm soapy water. Residual corrosion and acid spillover can be removed with a baking soda and water mixture using one small box of soda to one gallon of water. **Remember, battery acid can be very damaging...wear rubber gloves, eye protection, and old clothes, and work in a well-ventilated and appropriate area for the task.** Battery residue can stain concrete. Next, re-face the contact surfaces of your battery terminals, as this will ensure good electrical contact with the new cables of your speed kit. While this can be done with a small file or sandpaper, the best tool for this task is our battery terminal re-facer, which insures a flat, smooth surface and maximum electrical contact between the terminal and the battery. Also, inspect the battery-water level in each cell of each battery and fill to the proper level. While the caps are off, wipe them with a moist rag and inspect them for cracks, clogged ventilation holes, or other damage. Lastly, check the condition of the battery hold-down bolts. If they are damaged, or corroded, replace them now. Once these steps are completed, you may install the batteries into the battery tray, remembering the importance of arranging the batteries just as they were when you removed them. Generally, it is easier to first install the

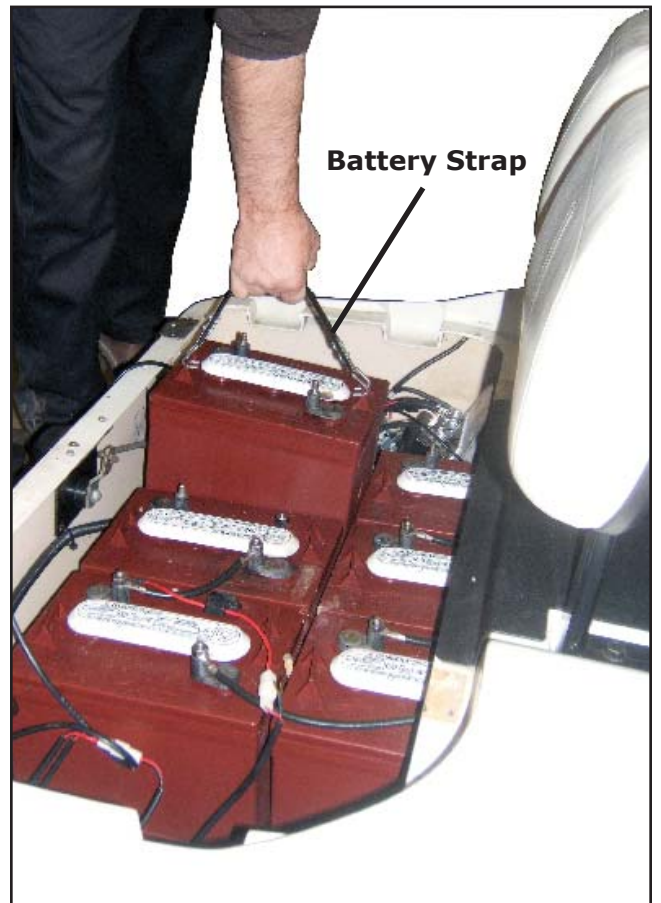

12. Battery Installation Example on EZGO

three batteries to the rear of the cart, followed by the three batteries in the front. The battery hold-down bolts create a bit of a balancing act, but with a little patience and persistence you will have all six batteries installed, and you will be able to set the hold-down plate over the bolts and secure them using the factory hardware and a 1/2" wrench.

- 13) BATTERY WIRING:** A note on battery wiring: With new cables and re-faced battery posts, you are prepared to make an excellent connection at each battery post. The last factor in a great connection is a good tight fit of the terminal to the post. You will want to tighten all of your lug nuts securely, but avoid over tightening. Putting too much effort into securing the nuts can distort the battery plates and care should be given to supporting the post while tightening. Stripped threads will lead to loose connections, increased heat, and premature failure. Battery lug nuts typically require 1/2" or 9/16" sockets...use whatever size socket fits your particular application. Torque nuts to 90-110 inch pounds.
- a) Locate the four (4) black/red coded cables, which are 7.5" long. Using the wiring diagram for reference, install one cable between the negative terminal of battery #1 and the positive terminal of battery #2. Install another 11.5" cable between the negative terminal of battery #2 and the positive terminal of battery #3. Install another 7.5" cable between the #3 negative terminal of battery #3 and the positive terminal of battery #4. Install the last 7.5" cable between the negative terminal of battery #4 and the positive terminal of battery #5. Tighten securely using the above-mentioned cautions.
 - b) Locate the black/red coded cable, which is 7.5" long. Using the wiring diagram for reference, install this cable between the negative terminal of battery #5 and the positive terminal of battery #6.
 - c) Before proceeding, ensure that the key is removed from the ignition switch.
 - d) Locate the 23" long red coded cable, which you installed in step 11b. Connect the free end of this cable to the positive terminal on battery #1. **It is critical that this connection is made accurately!** This wire should run only from the battery side large threaded lug of the solenoid directly to the positive terminal of battery #1. Double-check your work before proceeding.
 - e) Locate the 55" long black coded cable, which you installed in step 11i. Connect the free end of this cable to the negative terminal on battery #6. **It is critical that this connection is made accurately!** This wire should run only from the "B-" bus bar of the speed controller to the negative terminal of battery #6. Double-check your work before proceeding.

14) ACTIVATION WIRING: Reference the Activation Wiring Diagram on Page 13

- a) **Solenoid:** The wiring for the solenoid will be the same wires that were removed. Remove the existing diode (small posts) and discard. Connect the red wire with the white tracer to the #1 small terminal. Connect the solid black wire to the small #2 terminal. When tightening the nuts make sure the lock washers are fully collapsed and the wire will not move. Again it is advised to use the opposing wrench technique of tightening to prevent damage.
- b) **Controller:** The seven wire harness with the yellow, white, green, yellow/w/black tracer, brown, pink, and blue wires is the harness you will be working with in this section.
 - 1) The yellow wire will connect to pin number one on the controller using the wire ends provided.
 - 2) The white wire will connect to pin number two on the controller using the wire end provided.
 - 3) The green wire will connect to pin number three on the controller using the wire end provided.
 - 4) The yellow wire with the black tracer will connect to the brown wire using the wire nut provided.
 - 5) The blue wire is not used for this system and should be taped.
 - 6) The pink wire is not used for this system and should be taped.
- c) After all the connections are secure, due to the location of the controller and solenoid, spray cote the connections with a non conductive sealer to protect from corrosion.
- d) Clean up any loose wiring by securing it neatly with the wire ties from the hardware kit. This will prevent the wires from becoming damaged through vibration and movement.

FINAL INSPECTION AND TESTING

At this time you should take a moment and review your installation and make sure that all cables have been connected to the appropriate terminal. Look for a loose connection, which you may have failed to tighten. Ensure that all of the smaller wires have been returned to their original locations. Once you are confident that all of your work is sound, reinstall the seat assembly on the cart to begin the testing procedure. Testing should only be done outside with at least 30 feet in front of and in back of the cart. If you have installed your kit inside a garage, you will have to push (**NOT drive**) the cart outside where ample space is available and perform the following procedures:

- 1) Ensure that the steering wheel is centered and the front wheels are pointed straight ahead.
- 2) Ensure that other people are not standing in front of or behind the cart during testing.
- 3) Place the cart in neutral and ensure that the parking brake is OFF.
- 4) With your left foot “over” the brake pedal, and your right foot OFF the throttle pedal turn the key switch on. Be prepared to apply the brake and turn the key off simultaneously, if the cart should move...it should NOT move. If the cart does move, remove the key, set the brake and check your wiring. If the cart did not move proceed to step 5.
- 5) Select the “forward” direction and SLOWLY apply pressure to the throttle. If the cart does not move forward SLOWLY, set the brake, remove the key, and check your wiring. If the cart does move forward slowly, proceed to step 6.
- 6) Select the “reverse” direction and SLOWLY apply pressure to the throttle. If the cart does not move backward SLOWLY, set the brake, remove the key, and check your wiring. If the cart does move, select the “forward” direction and drive the cart to an appropriate open area to check the acceleration and top speed. If the cart performs properly, proceed to step 7.
- 7) Remove the seat once again and spray the battery posts, nuts, and terminals with Battery Terminal Protection Spray. This coating will protect your batteries and extend their life. Replace the seat cushion, and enjoy your new speed kit!

INDEMNIFICATION AND INSURANCE AGREEMENT

High speed motor installation should be performed by a professional. The high speed motor purchaser assumes sole and entire responsibility for, and shall indemnify and save harmless Mattison Avenue Corporation (d.b.a. Buggies Unlimited), from any and all claim, liability, responsibility, and damage, or any costs or expenses resulting from any loss of life or injuries or claimed injuries to persons or property that may be sustained in connection with the use of any product before or after purchase, including but not limited to high speed motors. The high speed motor purchaser also shall indemnify Mattison Avenue Corporation (d.b.a. Buggies Unlimited) and save Mattison Avenue Corporation (d.b.a. Buggies Unlimited) harmless with respect to any and all liability that may be incurred.

Golf carts are recommended for use only by those aged 16 and older. Golf carts can be especially hazardous to operate. Always remember that riding and alcohol/drugs don't mix. Never ride on public roads. Never carry more than two passengers (except shuttles and trams). Never engage in stunt driving. Avoid excessive speeds and be particularly careful on difficult terrain. Buggies Unlimited reserves the right, at any time, to discontinue or change specifications, prices, designs, features, models or equipment without notice and without incurring any obligation.

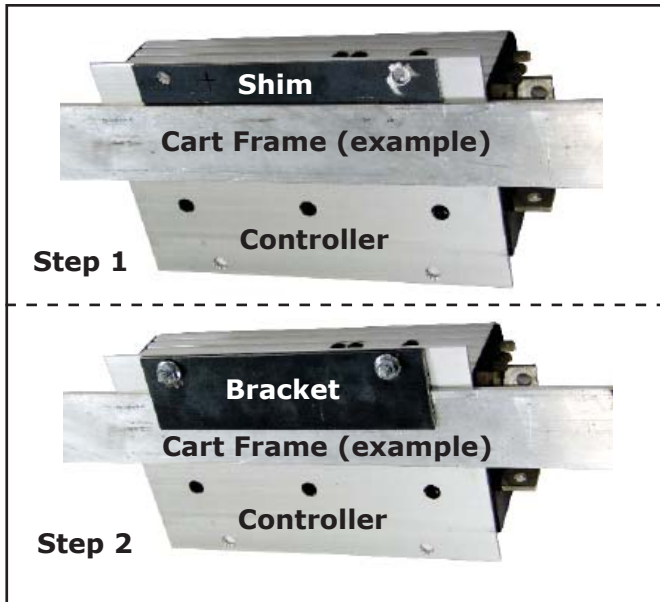

Controller Bracket Installation

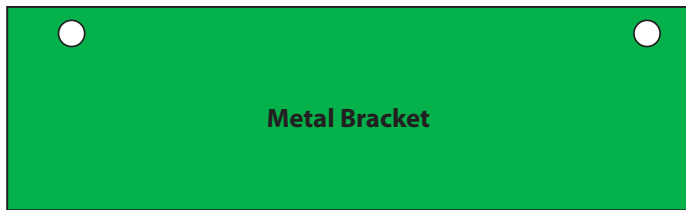

Metal Brackets Included in Kit

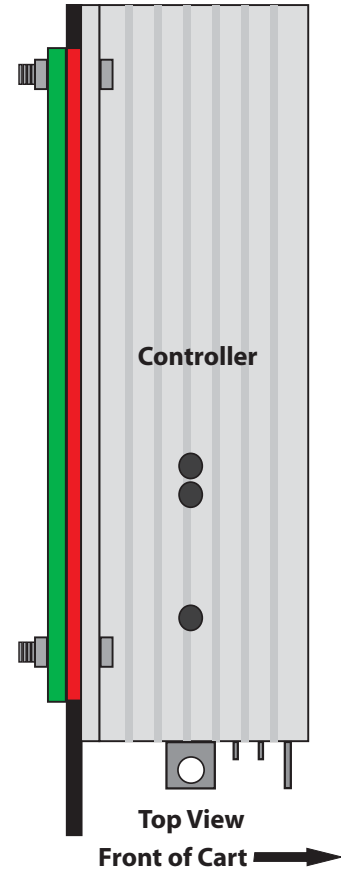

Align the controller with the driver's side edge of the frame.

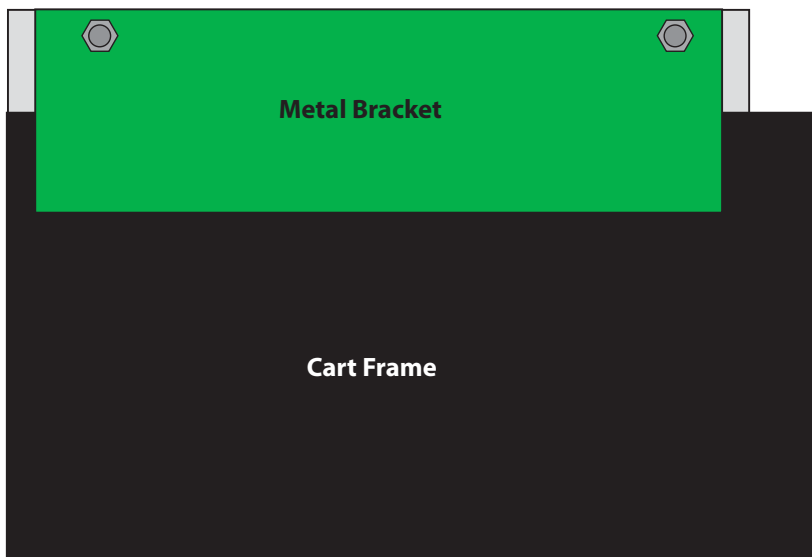

Back View

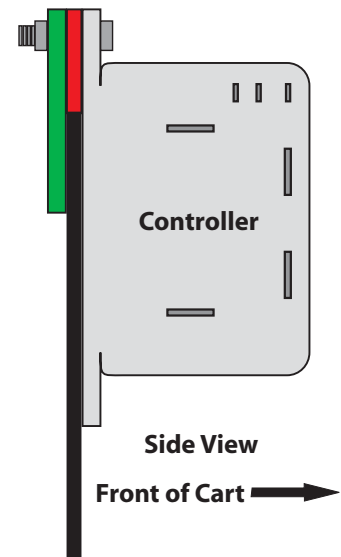

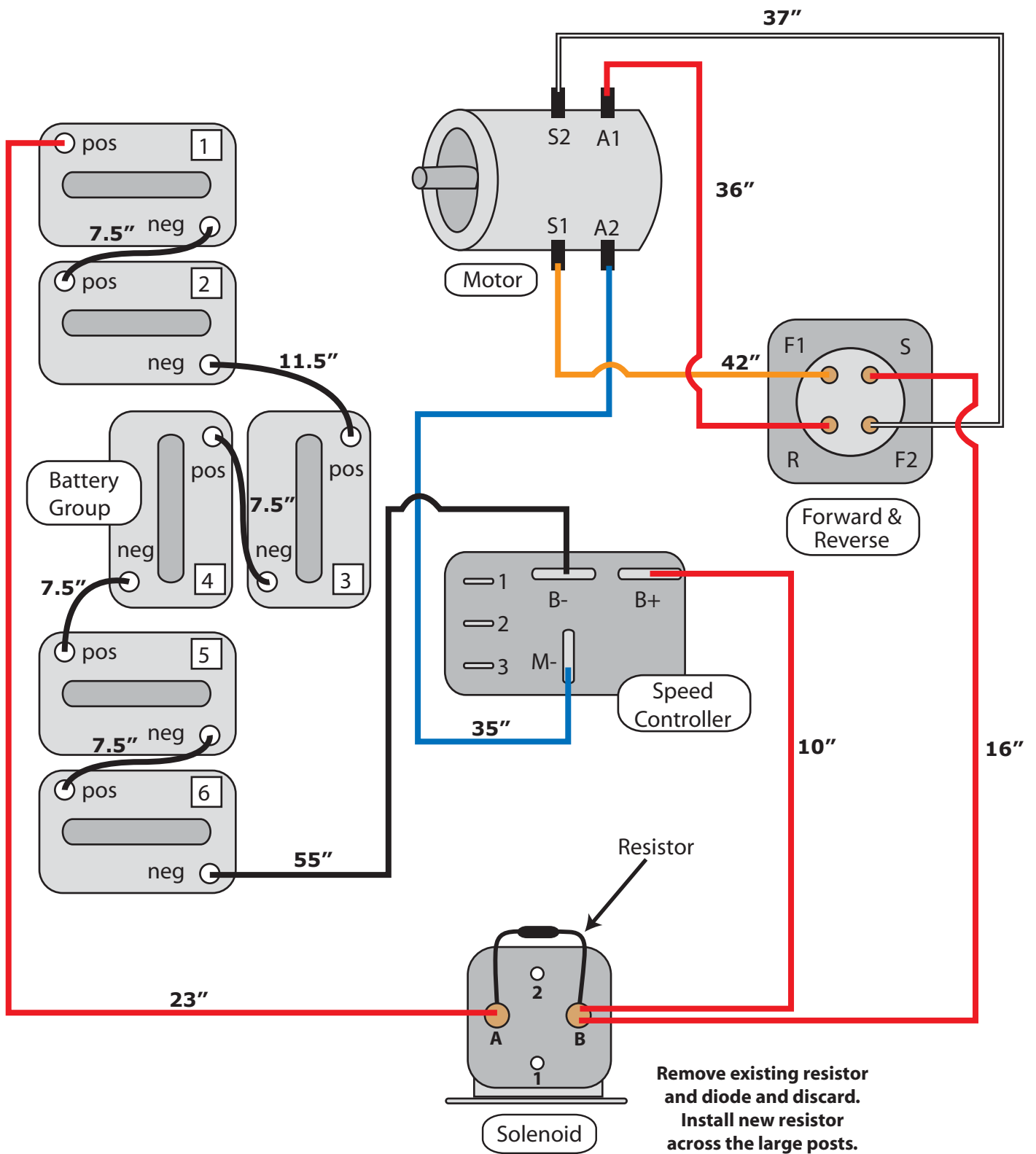

STQ YA3 3001K Heavy Gauge Wiring

Buggies Unlimited
 1-888-444-9994
 www.buggiesunlimited.com

© Copyright 1997-2008 Buggies Unlimited. All Rights Reserved.

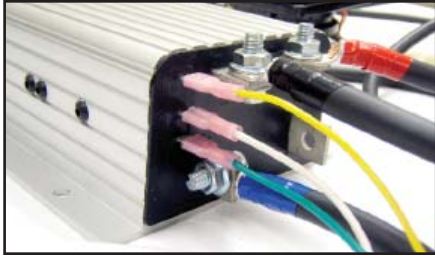
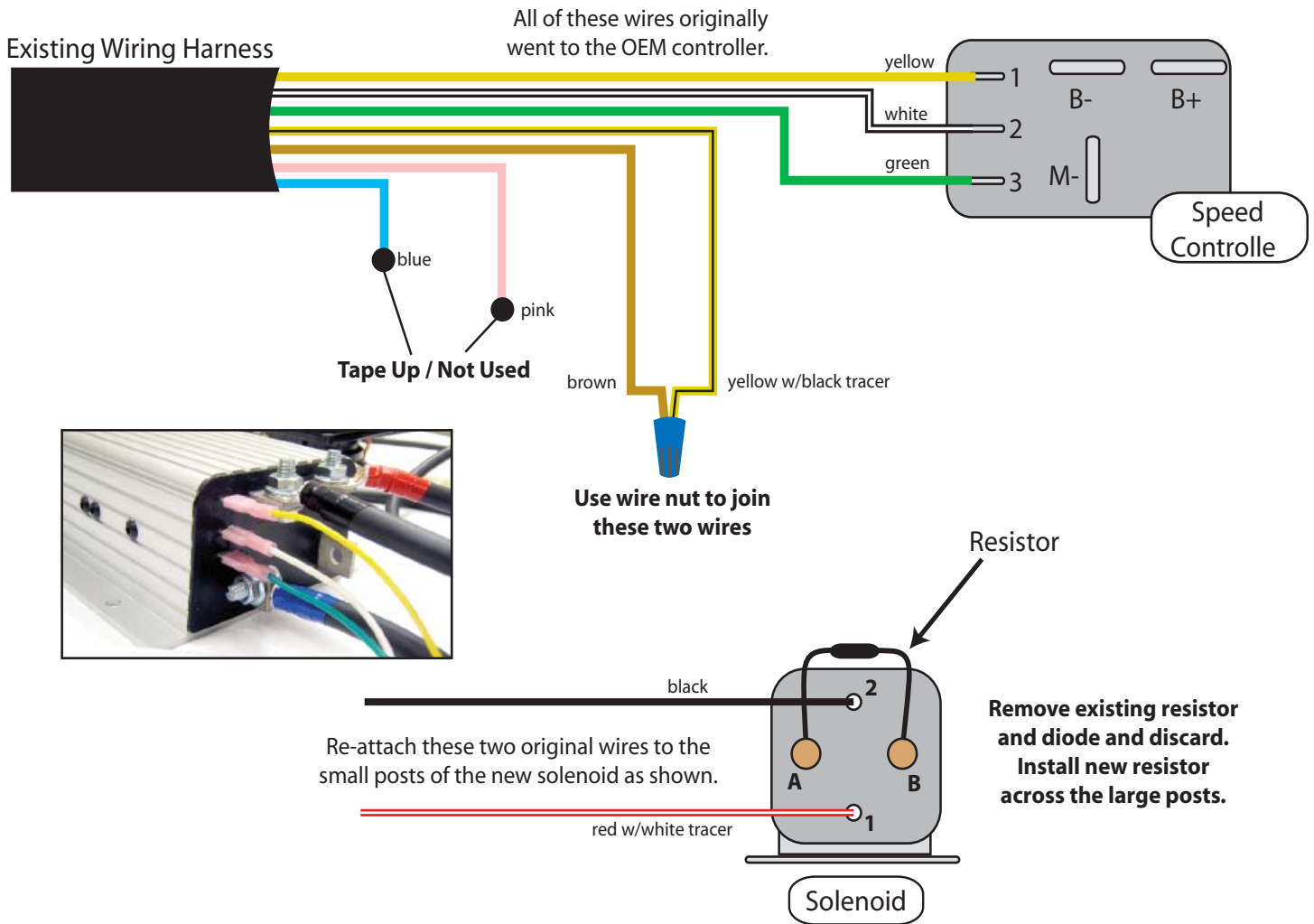

STQ YA3 3001K Activation Wiring

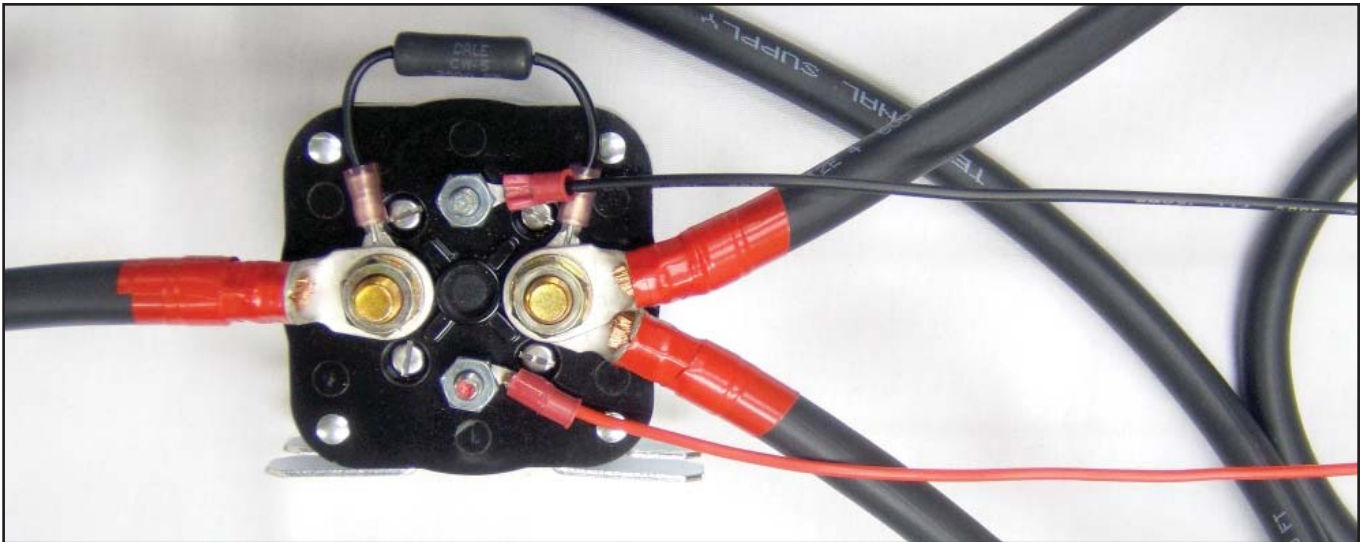

Buggies Unlimited
 1-1-888-444-9994
 www.buggiesunlimited.com

© Copyright 1997-2008 Buggies Unlimited. All Rights Reserved.