

**YAMAHA G14
INSTALLATION
INSTRUCTIONS**
Revision 082306

Before installing your DoorWorks™ enclosure, remove the windshield from the cart. Reattaching the windshield IS THE FINAL STEP. NOTE: After reattaching the windshield you may notice that your windshield clamp may not work the way it used to. Some windshields are made with clamps mounted on the windshield rather than the roof strut. In this case, the fabric will not allow the clamps to wrap around the front roof strut. This can easily be fixed. You will need to cut a slot in the fabric to allow the windshield clamps to attach around the roof strut. Raise the windshield and locate where the clamps will strike the roof strut -this is where the slot needs to be made. Note there are two lines of stitches

used to attach the Velcro®. Next, with a sharp blade, (a razor knife works good) make a cut between the two lines of stitches. You will cut through the fabric and Velcro® on both sides. The stitches are made with a lock-stitch machine, so even if you slip and cut them, they shouldn't continue to ravel. The vinyl material we use is a "rip-stop" style, a little more expensive, but it remains very stable even after it is cut. Sunbrella fabric could fray slightly after cutting, some dealers will seal the edges of Sunbrella with heat (soldering iron works great.)

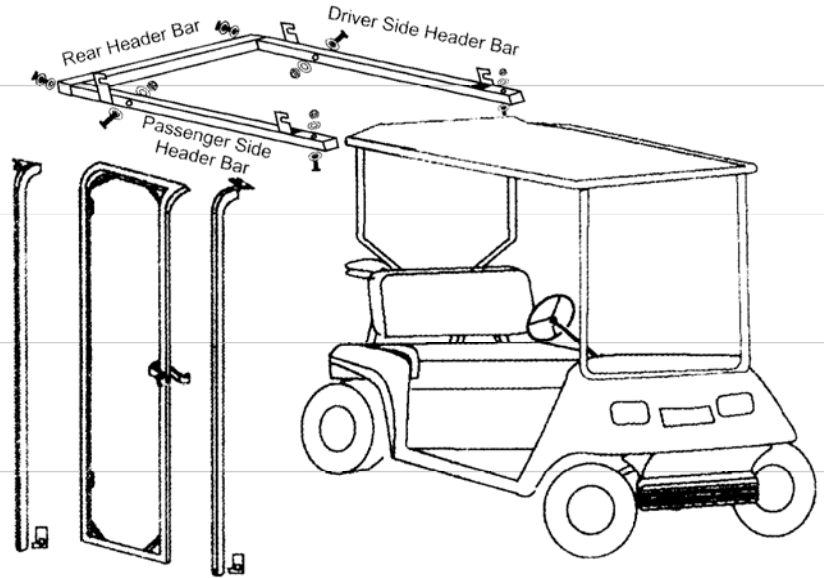

PACKING LIST

2 SIDE HEADER BARS	2 10-32 x 1 1/4" HEX HEAD SCREWS	4 1/4" SS WASHERS
1 REAR HEADER BAR	4 1/4-20 x 2 1/4" BOLTS	8 10-32 NYLOCK NUTS
2 REAR DOOR POSTS	2 1/4-20 x 2 1/2" BOLTS (gas powered only)	3 PIECES OF VELCRO®
2 DOORS	2 10-32 x 1" SELF-TAPPING HEX HEAD SCREW	1 BACK PANEL
2 FRONT DOOR POSTS	2 10-32 x 1" HEX HEAD SCREWS	2 FRONT PANELS
2 DOOR LATCHES	2 10-32 x 1 1/2" PHILLIPS BOLTS	2 DOOR PANELS
4 VINYL GRIPS	2 #10 LOCK WASHERS	1 WINDOW PANEL
4 PLASTIC SPACERS	10 #10 WASHERS	1 DRY CLUB™
4 "J" HOOKS	4 1/4-20 NYLOCK NUTS	2 STANDOUT STRAPS

1 INSTALL SIDE HEADER BARS

Loosen the factory roof bolts that secure the cart top to the cart frame as shown in the diagram to the right. Slide the slotted tabs on the Side Header Bars to the front of the cart until the open slots fully engage the roof bolts, then retighten. Loosely attach the 10-32 x 1 1/4" bolt, washer and Nylock nut in the hole shown in the diagram to the right. Repeat this process on both sides of the cart.

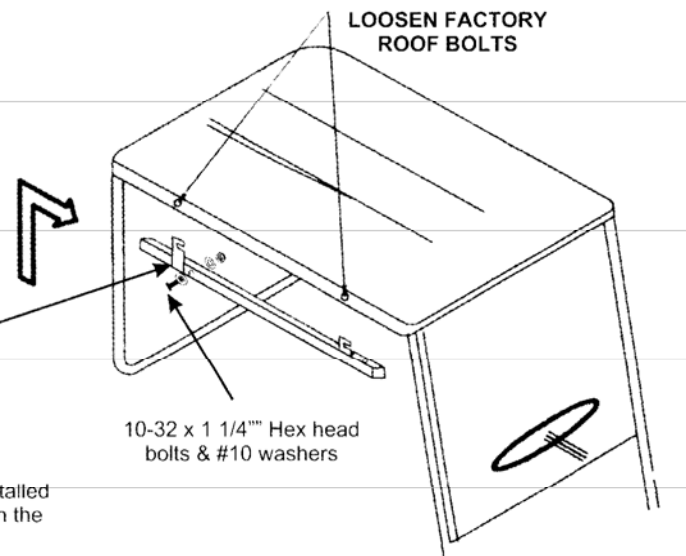
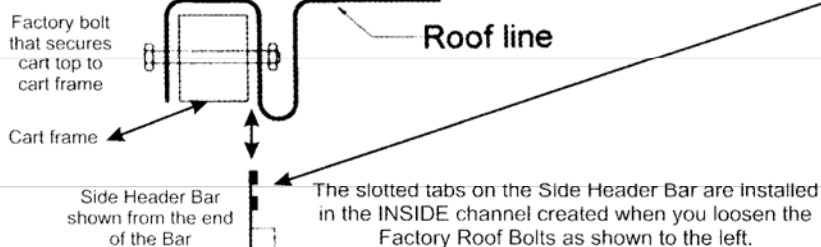

2 ATTACH REAR HEADER. Now that the Side Header Bars are in place, attach the Rear Header Bar to the Side Header Bars with 10-32 x 1" self-tapping hex head screw, washer and #10 lock washer as shown in the photo below. Tighten.

10-32 x 1" self-tapping hex head bolts, washer & #10 lock washer

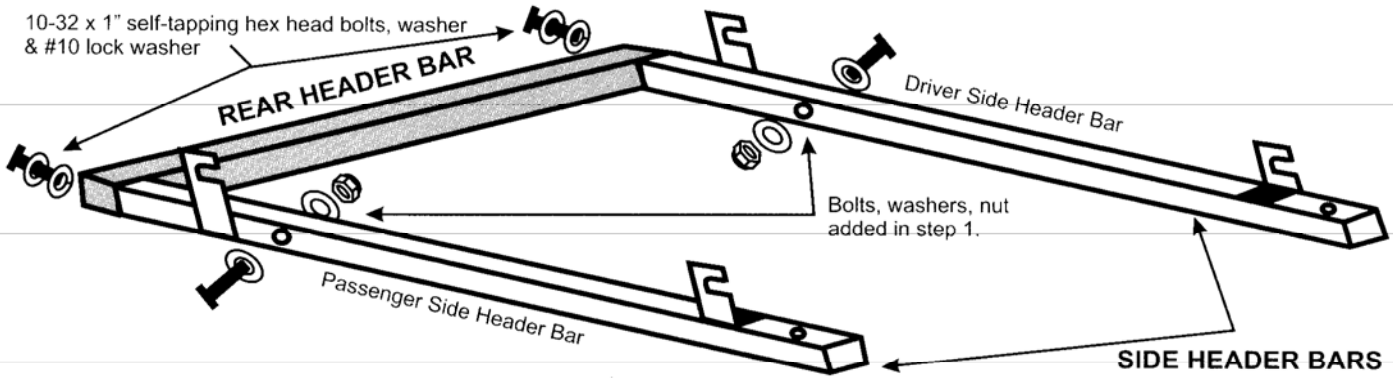

3 ATTACH DOOR POST "J" BRACKETS. THE PHOTOS BELOW SHOW THE "J" BRACKETS IN PLACE ON THE CART AFTER STEPS 4 & 5 ARE COMPLETED. However, Step 3 only wants you to loosely attach the "J" brackets to the bottom of the door posts using a 1/4-20 x 2 1/4" bolt and (2) 1/4-20 washers and a Nylock nut. For gas carts, use the elongated "J" brackets (shown to the right) on the Rear Door Posts ONLY.

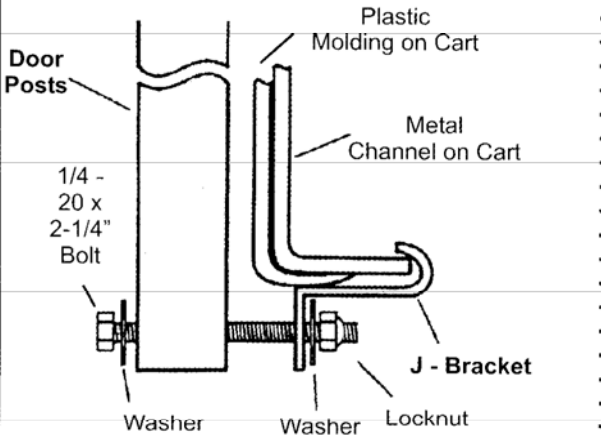

THIS PHOTO FOR GAS CARTS ONLY

NOTE: ON SOME GAS CARTS, IT MAY BE NECESSARY TO USE THE ELONGATED "GAS" "J" BRACKET ON THE REAR DOOR POSTS ONLY.

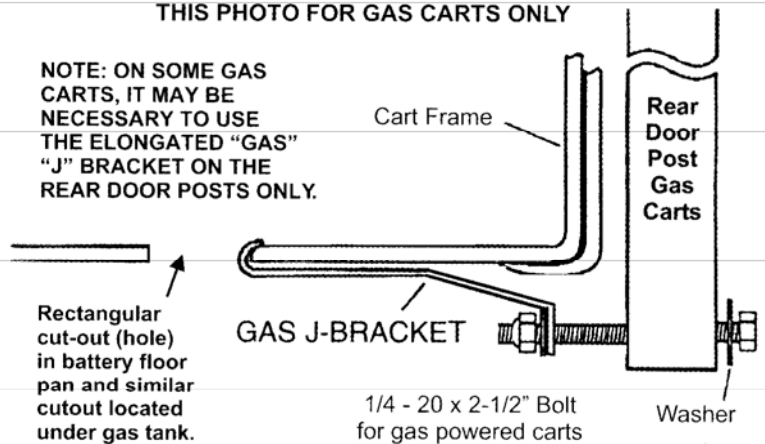

4 INSTALL THE REAR DOOR POST WITH THE DOOR PLACED ON THE HINGES. Place the hinges of the passenger Door onto the corresponding Rear Post. (The correct Rear Post will be the one with the tabs pointing to the rear of the cart. The correct Door will be the Door with the hinges on the LEFT.) With your left hand, attach the "J" bracket to the metal frame underneath the cart as shown in photo above. Then, lift the Door Post and Door up and slide the slotted tab behind the bolt and washer you attached in step one. Center the slot behind the bolt and washer and tighten the Nylock nut. The correct position of the door post is achieved when the top edge of the door is running parallel with the Side Header Bar. Gently tap the bottom of the door post in the direction needed to attain parallel - then securely tighten the top and bottom bolts. (NOTE: The slotted tap at the top of the Rear Door Post allows for fine adjustment if needed.)

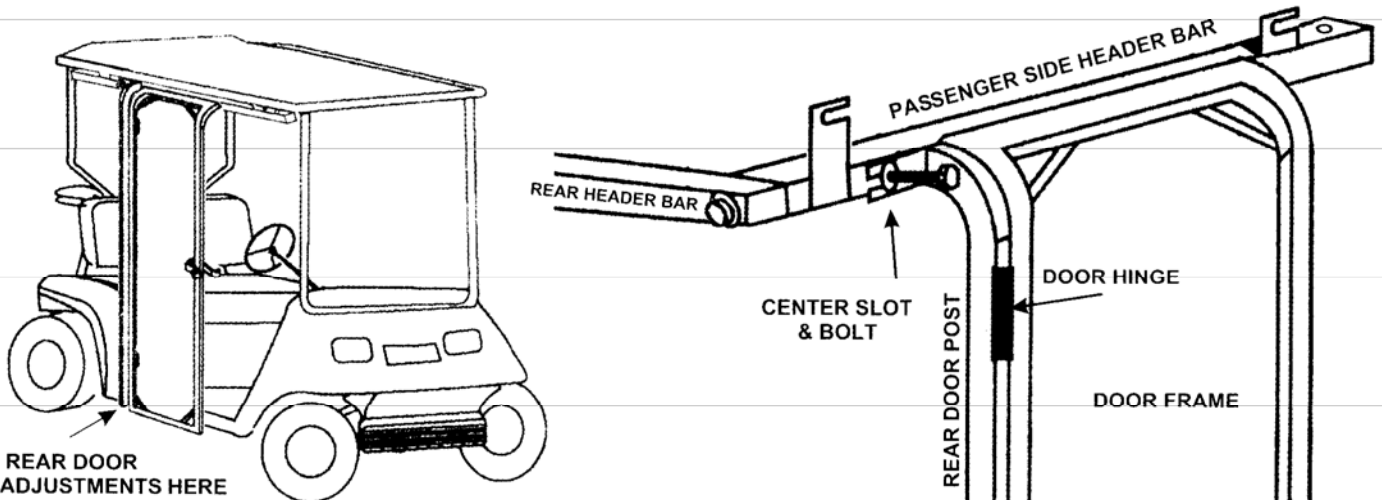

5

INSTALL THE FRONT DOOR POST. (The Front Door Posts are the Posts that do not have hinges on them.) Loosely attach the "J" bracket at the bottom of the Front Door Post in the same way you attached the Rear Door Post. Then, raise the Front Door Post up and place the tab over the Side Header Bar. Place a 10-32 x 1" bolt and washer through the underside of the Side Header Bar through the Side Header Bar hole and Door Post slot. Add another washer and Nylock nut and finger tighten. Tap the Front Door Post so that there is an approximate 1/4" gap between the Door and the Post. When you have achieved proper alignment, securely tighten all bolts. Repeat the process on the other side.

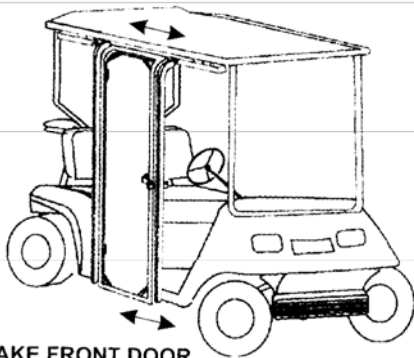

MAKE FRONT DOOR ADJUSTMENTS HERE AND AT THE TOP IF NECESSARY

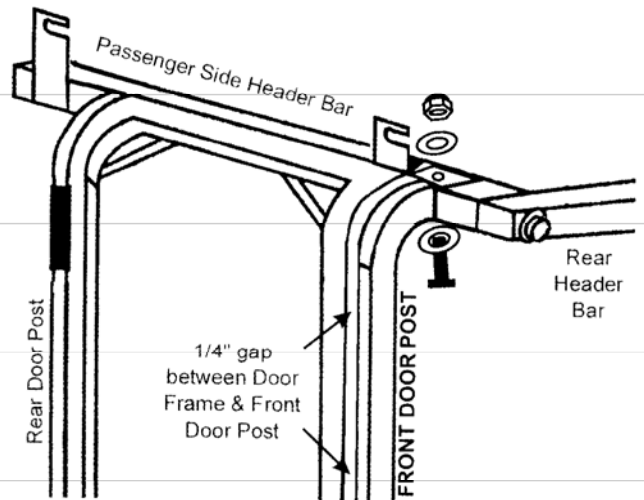

6

Install forward cover panels.

Wrap the edge flaps of the cover panel around the front roof post, the header, and the front door post by attaching the hook and loop (Velcro®). Adjust the cover until it is smooth and tight. Seal the bottom of the front panel, attach the 8" piece of adhesive back loop (Velcro®) to the piece of hook sewn near the bottom. While holding in position, peel the paper backing from the adhesive and press against the cart.

TIP To ensure the best adhesion, clean cart surface with rubbing alcohol.

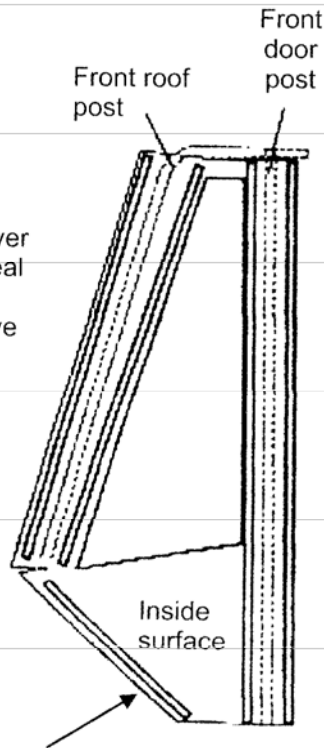

8" adhesive back loop (Velcro®) goes here

7

Install door cover panels.

(TIP: Some people have found it easier to perform Step 8 before Step 7)

Place pockets at top of the cover over the corners at the top of the door.

Notch for door latch.

Wrap the edge flaps of the cover panel around the door frame.

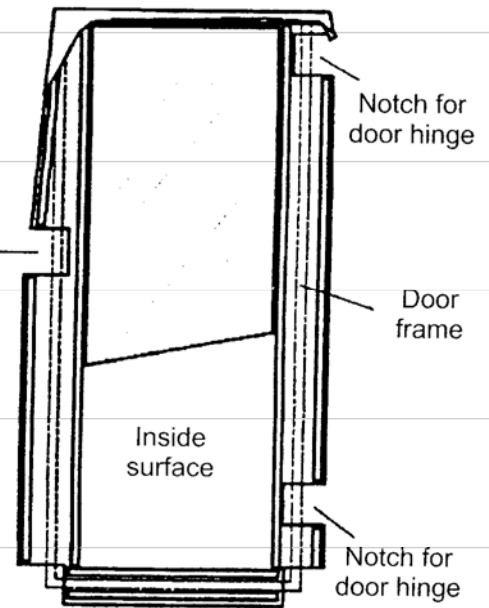

P-Side door cover panel

8

Assemble the door latches. Using a 10-32 1 1/2" Phillips screw, locknut, and 2 plastic spacers, attach a door latch to each door frame.

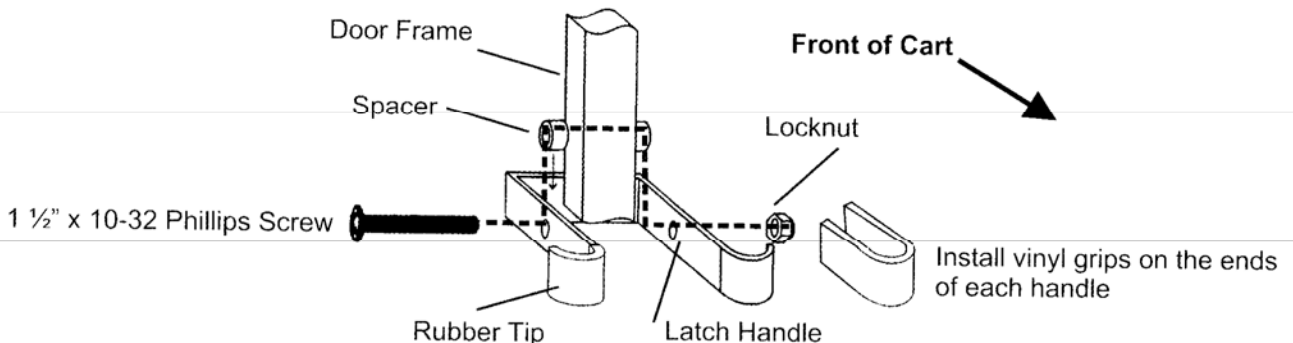

9

LOOKING AT THE REAR OF THE CART.

Install back cover panel. A. Find the 2 outer openings for cart buckle and 2 slits for straps located below the open window. On the cart, unbuckle the bag holder straps. Push the buckles and the straps through the 4 openings from the inside of the cover panel. (See detail)

B. Wrap the top edge flap over header and attach hook-and-loop (Velcro®). (B)

C. With doors removed, wrap the side edge flaps around the rear door posts, attach hook-and-loop (Velcro®).

D. Use hook-and-loop (Velcro®) strips to secure panel to the rear roof support and seat frame. The flap on the bottom goes under the basket, on the body of the cart, to provide a protected storage space under the basket. Using 20" piece of adhesive back loop (Velcro®), secure the flap to the cart body under the basket.

NOTCHES FOR
DOOR HINGES

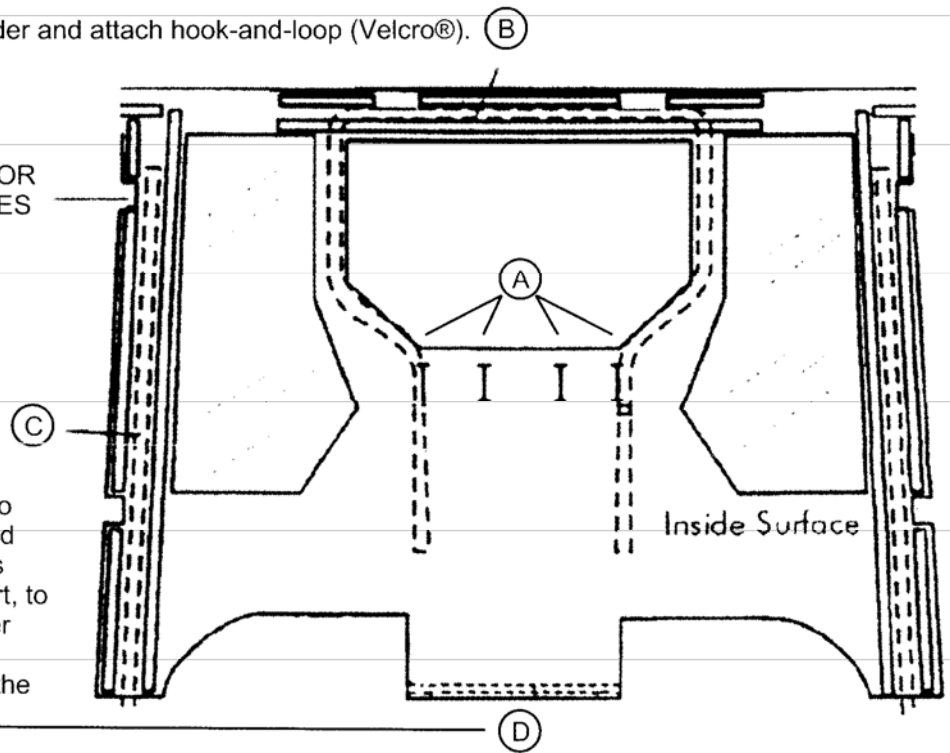

10 The "stand-out strap" secures the door open while driving AND prevents the door from rubbing against the rear wheel.

1) Open the door to rear of cart. Place the loop of the "stand-out strap" around the door latch, then pull the loose end of the strap to tighten the loop securely around the latch, while holding the PVC pipe.

2) To secure the "stand-out strap" to the cart, put this end of the strap ALONG WITH the cart's bag strap through the buckle that holds the clubs on the cart. Pull tight and lock buckle.

NOTE: Now that you have your new enclosure - you are going to become very popular in bad weather golf. Do not assume that your passenger has used the "Stand-out strap" correctly. Inspect that the strap is tight and that the door cannot rub the rear tire. DAMAGE TO THE DOOR AS A RESULT OF TIRE RUB IS NOT COVERED BY THE WARRANTY.

The "stand-out straps" conveniently store inside the DryClub™ cover when not in use.

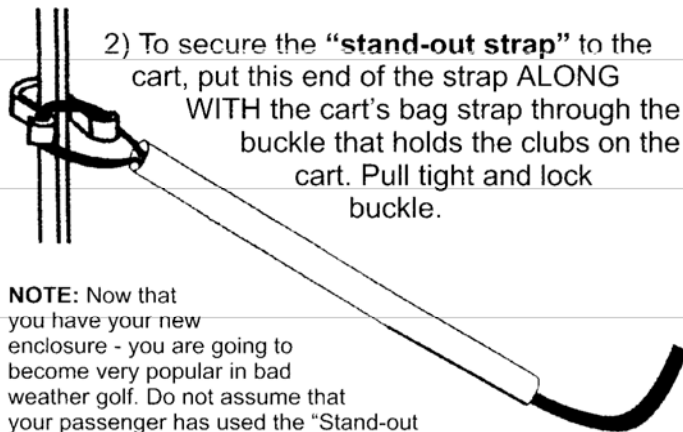

11 REAR WINDSHIELD is designed with "loop" (Velcro®) on both sides so that it can be fully attached to the enclosure, or can be rolled up and held in place by the Velcro®. See Illustration below.

12 DRY CLUB™ CLUB COVER AND REAR WINDSHIELD ILLUSTRATION

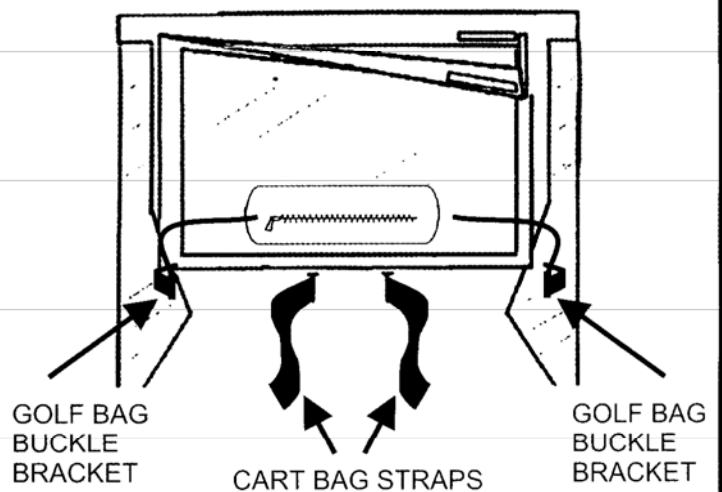

The DryClub™ club cover sits outside the cart above the buckle brackets. The 2 straps enter through the outer openings and connect with each other inside the cart above the sweater basket.