

# UNIVERSAL 4 & 5 PANEL REAR VIEW MIRROR Installation Instructions



## Parts List

Figure 1 Key	Qty.	Description	Figure 1 Key	Qty.	Description
1.	1	Panel Mirror	4.	4	Self-tapping metal screws
2.	1	Long bolt	5.	4	Nuts
3.	2	Slotted Brackets	6.	2	Adjusting knobs

## FITTING

1. Before proceeding, check that all the parts listed above are in the parts bag.
2. Assemble the parts to both ends of the Panel Mirror as shown in Figure 1 below.

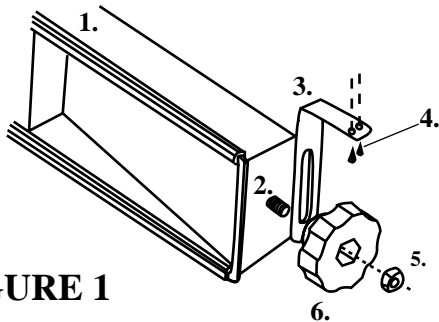

**FIGURE 1**

3. Finger tightening of all the bolts and knobs will be adequate until the mirror is finally mounted.
4. The actual mounting points for the Panel Mirror must now be selected (Figure 2).
5. Hold the assembled mirror up to the selected mounting point. Figure 2 shows a rough idea of where the Panel Mirror should be mounted. Your own preferences may vary, so move it around a bit until you are satisfied. Take care to ensure the movement and adjustment of the mirror.

6. Holding the mirror with one hand, mark the holes to be drilled into the top supports, through the two holes in each slotted mounting bracket. Ste the mirror aside and drill these two holes in each top support, using a 1/8" drill bit.

7. Remove the mounting brackets from the mirror and mount them securely to the previously drilled points with the four self-tapping metal screws provided.

8. The mirror can now be reattached to the mounting brackets. Adjust the mirror to achieve the best possible viewing. Finally, tighten down the nuts on the mounting brackets and the knobs at each end of the Panel Mirror.

9. To readjust the mirror for other drivers, simply loosen the knobs slightly on either end of the mirror and retighten after adjustment has been made. **DO NOT OVER TIGHTEN** to avoid stripping threads or breaking a knob.

10. To clean the mirror glasses, use any proprietary window cleaner. **DO NOT USE** any abrasive type of cleaner such as those used on car body work or kitchen appliances or utensils.

**FIGURE 2**

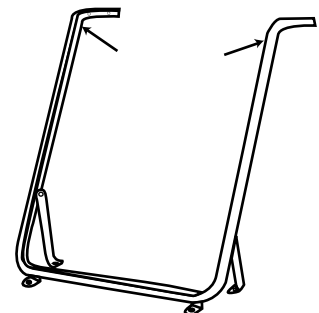

Buggies Unlimited  
888-444-9994  
buggiesunlimited.com