

CLUB CAR PRECEDENT

- REAR SEAT KIT
- REAR SEAT "2-in-1" COMBO
- REAR SEAT "3-in-1" COMBO

HARDWARE INCLUDED:

- (2) 8mm x 60mm BOLTS
- (2) 8mm x 90mm BOLTS
- (4) 1" SPACERS
- (2) 1/8" "L" BRACKETS (LARGE)
- (2) 1/8" "L" BRACKETS (SMALL)
- (8) 1-1/2" x 1/4-20 BOLTS
- (8) 2-1/2" x 1/4-20 BOLTS
- (4) 3" x 1/4-20 BOLTS
- (2) 3-1/2" x 1/4-20 BOLTS
- (2) 3" x 1/4-20 CARRIAGE BOLTS
- (4) 4" x 1/4-20 BOLTS
- (28) 1/4-20 NUTS
- (56) FLAT WASHERS
- (4) #14 x 2" TECK SCREWS

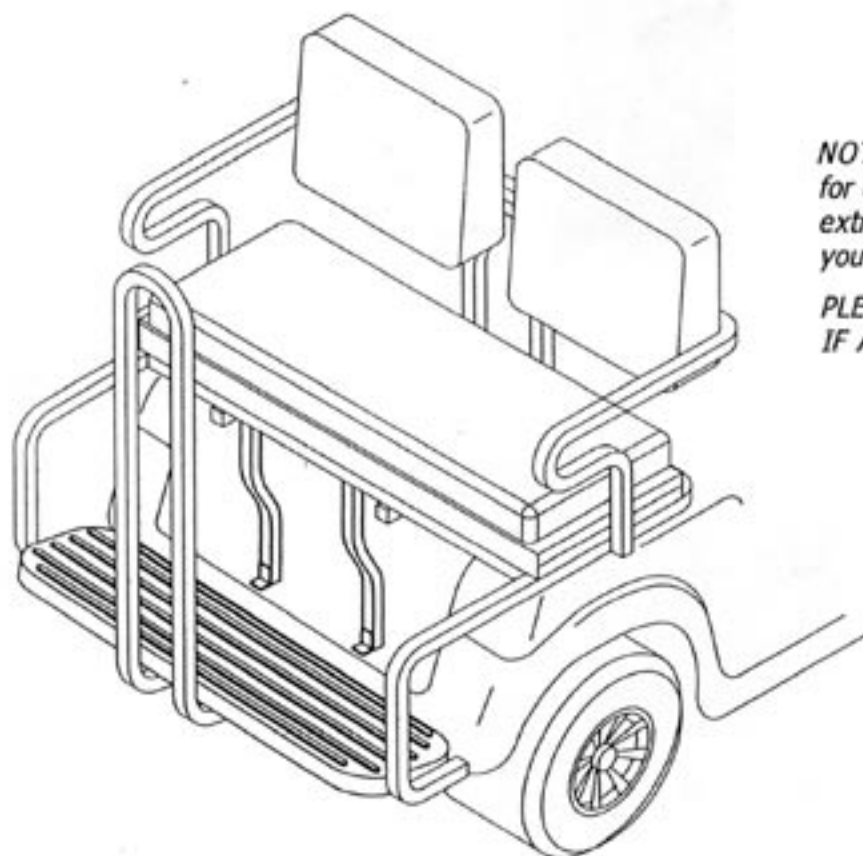

NOTE: Some hardware is specific for certain seat kits. You may find extra hardware remaining after your installation.

PLEASE CONTACT SUPPLIER IF ANY HARDWARE IS MISSING.



TOOLS REQUIRED:

- 17/64" DRILL BIT/DRILL
- 7/16" SOCKET
- 7/16" WRENCH
- 13mm SOCKET

STEP 1: MOUNTING MAIN SUPPORTS

FOLLOW SEQUENCE BELOW; *FINGER TIGHTEN ONLY UNTIL UNIT IS FULLY ASSEMBLED.*

- 1) REMOVE SEAT BACK AND MOUNTINGS.
USE NEW SEAT BACK MOUNTING TUBES AS TEMPLATES.
- 2) BOLT MOUNTING TUBES ONTO SEAT BACK AS SHOWN.
(ALIGN TOP OF TUBES WITH TOP OF MOLDED RIDGES).
- 3) MOUNT SUPPORT TUBES AS SHOWN.
- 4) REMOUNT SEAT BACK ONTO SUPPORT TUBES.
- 5) INSTALL REAR TOP FRAME IF APPLICABLE.

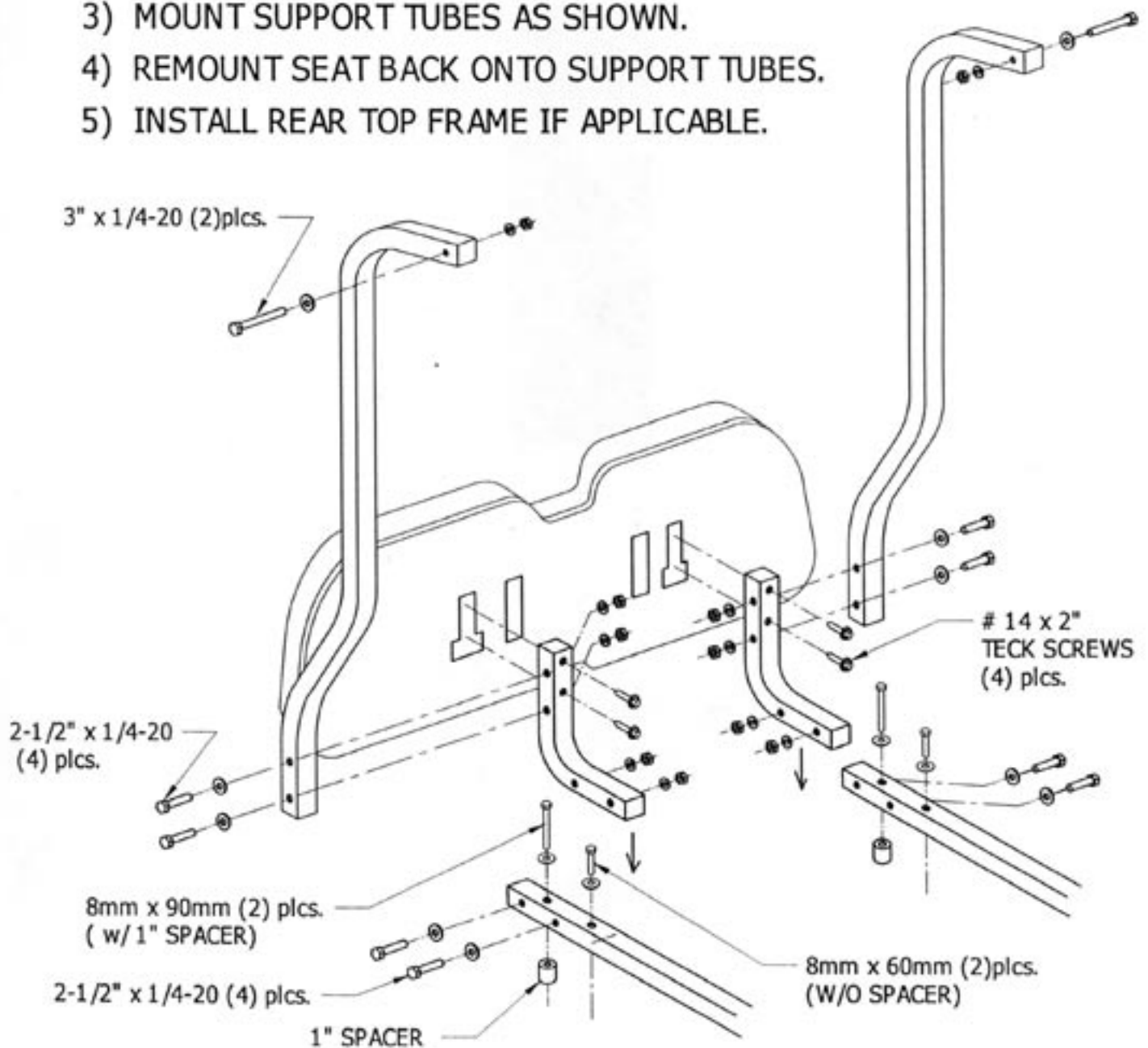

STEP 2: FINAL ASSEMBLY

FOLLOW SEQUENCE BELOW; *FINGER TIGHTEN ONLY UNTIL UNIT IS FULLY ASSEMBLED, THEN TIGHTEN COMPLETELY.*

- 1) MOUNT 1/8" "L" BRACKETS (SMALL) TO LOWER CENTER SUPPORT TUBES; (FACING AS SHOWN.)
- 2) BOLT CENTER SUPPORTS TO BAGWELL FLOOR USING EXISTING HOLES.
- 3) USING STUDS ON UNDERSIDE OF FOOTREST, MOUNT ASSEMBLY TO CAR WITH SUPPORT TUBES BELOW CAR AS SHOWN.

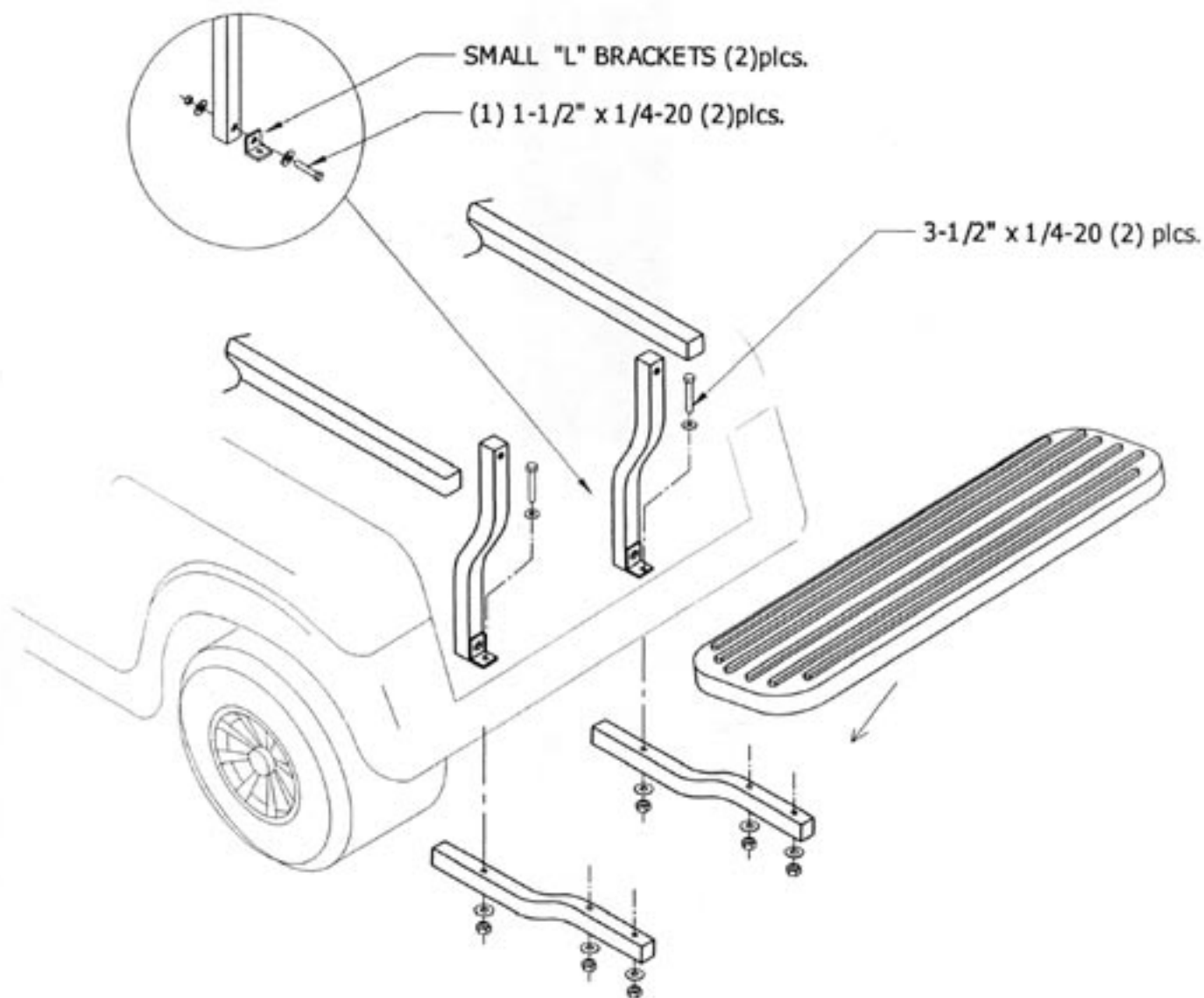

FOLLOW SEQUENCE BELOW; FINGER TIGHTEN ONLY UNTIL UNIT IS FULLY ASSEMBLED, THEN TIGHTEN COMPLETELY.

- 7) ATTACH SEAT BACK CUSHIONS TO SEAT ASSEMBLY. MOUNT SEAT ASSEMBLY ONTO CENTER SUPPORTS; BOLT ON "L" BRACKETS AS SHOWN; STANDARD SEAT REQUIRES ONE PLACEMENT / "2 IN 1" AND "3-IN-1" COMBO VERSIONS REQUIRE THE OTHER PLACEMENT.
NOTE: CROSS BRACE IS ALSO REQUIRED WHEN INSTALLING "3-IN-1" COMBO SEAT KITS.
- 8) MOUNT SIDE TUBES INTO SEAT ASSEMBLY AND ONTO THE STEP. USE SPACERS WITH "COMBO" KITS.
- 9) MOUNT OPTIONAL CENTER HANDLE, (REQUIRED WITH "2 IN 1" AND "3 IN 1" COMBO KITS. IF HANDLE IS NOT USED, IT IS RECOMENDED TO CUT OFF EXTENDED STUDS BELOW STEP.

