

DSA CC5 CVR CFBR, DSA CC5 CVR WDGR & DSA CC5 CRV TTAN

Dash Installation Instructions for Club Car 1982-2007 DS Models

Please remember to wear appropriate eye protection.

Dash Installation:

Disconnect the battery cables. Remove the dash panel and key switch. Remove the steering wheel by loosening the shaft nut (**Figure F**). Leave the nut in place, until the steering wheel is loose. Place your knees and arms under the steering wheel and brace your feet on the dash and rock the steering wheel back and forth (with great force) while pulling and pushing upward (**Figure G**). Another option is to cut the dash as shown (**Figure H**).

Key Switch hole mounting:

For the new style Black switch (**Figure B**) ream the mounting hole to .812 and for the old style Gold switch (**Figure C**) ream the mounting hole to .750. A reamer (**Figure A**) or stone grinding wheel can be used. To mount the new style switch the use of two mounting nuts is required (**Figure B**). The old style switch will only require a single nut that comes with the switch (**Figure C**). The rectangular battery indicator hole can easily be cut with the use of a dremel tool or similar cutting devise.

Dash Alignment:

Align the edge of the custom dash along the inside of the lip of the front body frame (**Figure I**). At each of the indentions along the perimeter of the custom dash (ten places), use a 1/8" drill to drill holes through the custom dash and frame underneath. **NOTE:** Using a 6" extended reach bit will lessen the possibility of damage to the dash. Use the included sheet metal screws to secure the custom dash to the frame.

Dash Door Installation:

Using door and frame as a template, drill 1/8" pilot holes in each corner. Insert screws and tighten with #2 phillips screwdriver.



A



B

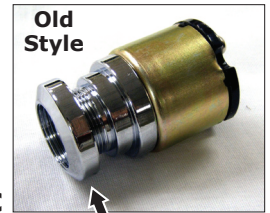

C

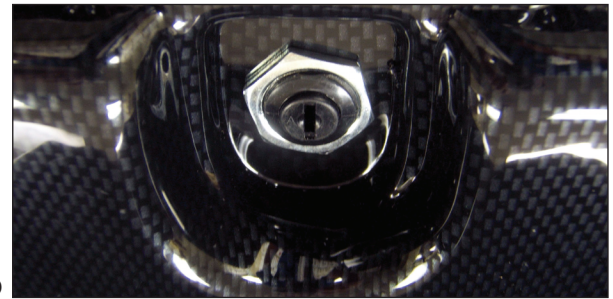

D

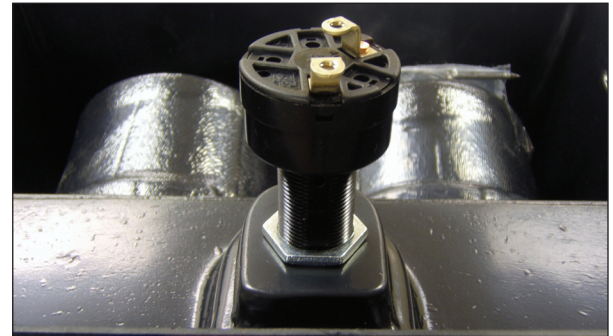

E



F



G

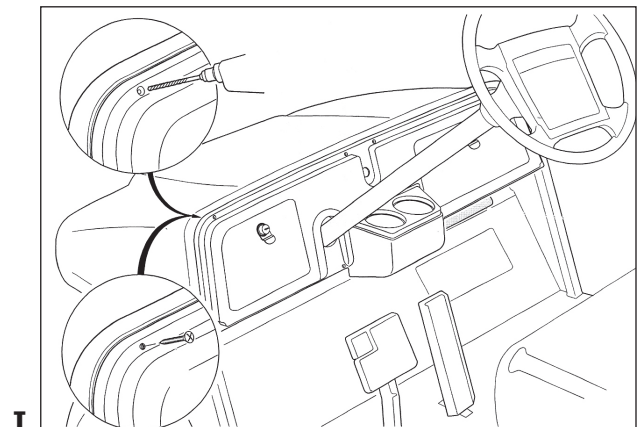

I

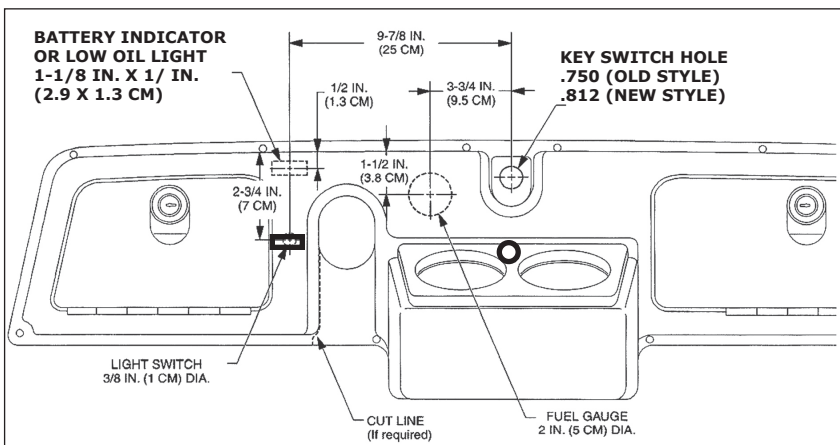

H

Copyright© 1997-2010. All Rights Reserved.